



F  
GB  
D  
NL  
E  
P  
I

**T8 > 350Nm / 400 > T9 > 800Nm**



**5045778C**

Lire attentivement cette notice avant toute utilisation.  
Read carefully these instructions before any use.  
Deze handleiding aandachtig doorlezen alvorens het systeem te gebruiken.  
Bitte gründlich vor der Anwendung lesen.  
Lea attentamente estas instrucciones de montaje antes de cualquier utilización.  
Let attentamente as instruções antes de proceder a qualquer utilização.  
Leggere attentamente queste istruzioni prima dell'uso.

S.A.S. au capital de 5 000 000 € - Z.I. Les Giranaux - BP71 - 70103 Arc-Les-Gray CEDEX - RCS GRAY B 425 650 090 - SIRET 425 650 090 00011 - n° T.V.A CEE FR 87 425 650 090

**835 – 845 – 940**

(F) Moteur standard - (GB) Standard motor - (D) Standardmotor - (NL) Standard motor - (E) Motor estandar  
(P) Motor standard - (I) Motore standard

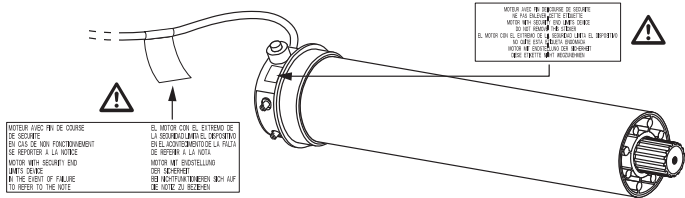

(F) Moteur avec manœuvre de dépannage - (GB) Motor with manual override - (D) Motor mit NHK - (NL) Motor met noodhandbediening - (E) Motor con mando manuale de seguridad - (P) Motor com comando de recurso  
(I) Motore con manovra di soccorso

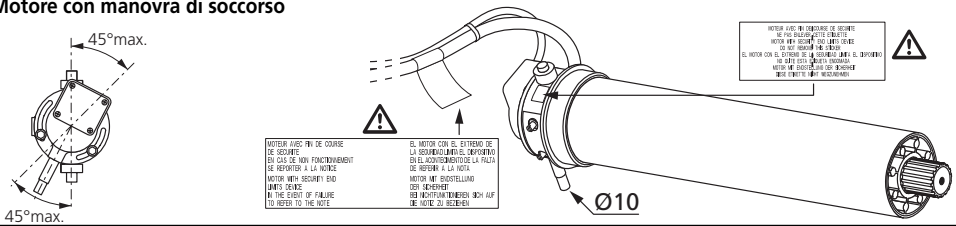

**950 – 960 – 980**

(F) Moteur standard - (GB) Standard motor - (D) Standardmotor - (NL) Standard motor - (E) Motor estandar  
(P) Motor standard - (I) Motore standard

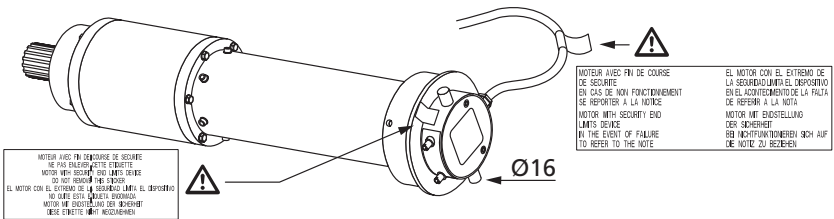

(F) Moteur avec manœuvre de dépannage - (GB) Motor with manual override - (D) Motor mit NHK - (NL) Motor met noodhandbediening - (E) Motor con mando manuale de seguridad - (P) Motor com comando de recurso  
(I) Motore con manovra di soccorso

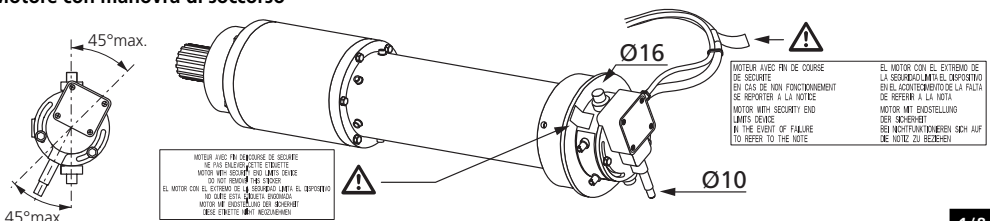

# 1

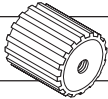
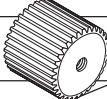
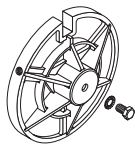
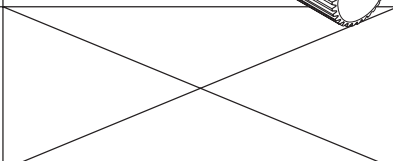
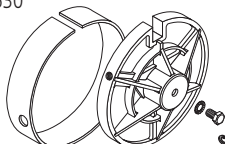
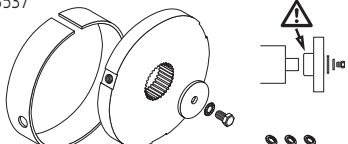
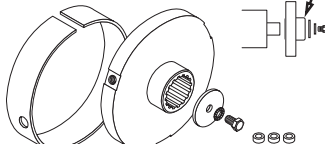
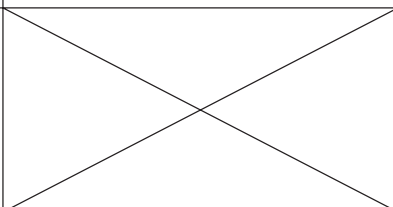
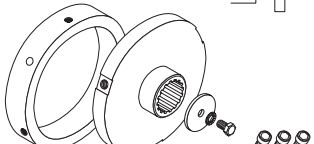
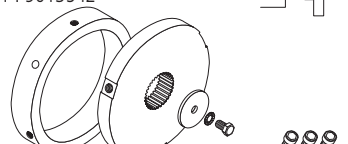
KITS	T835 - T845 - T940 	T950 - T960 - T980 
Ø124	9013529 	
Ø127	9013530 	9013537 
Ø131 Ø133	Ø131: 9013531 Ø133: 9013532 	
Ø149 Ø158 Ø160 Ø168 Ø181	Ø149: 9013533 Ø158: 9013534 Ø160: 9013535 Ø168: 9013536 	Ø149: 9013538 Ø158: 9013539 Ø160: 9013540 Ø168: 9013541 Ø181: 9013542 

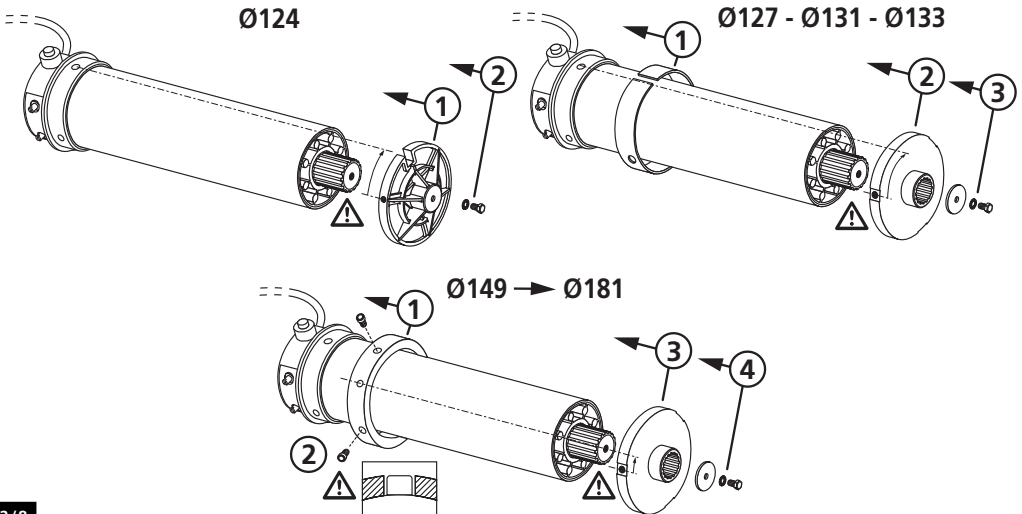

# 2

MONTAGE DU MOTEUR DANS LE TUBE - FITTING THE MOTOR IN THE TUBE - MONTAGE VAN DE MOTOR IN DE WIKKELBUIS  
 FIXIERUNG DES MOTORS IN DER WELLE - MONTAJE DEL MOTOR EN EL EJE - MONTAGEM DO MOTOR NO TUBO - MOTAGGIO NEL MOTORE DEL TUBO

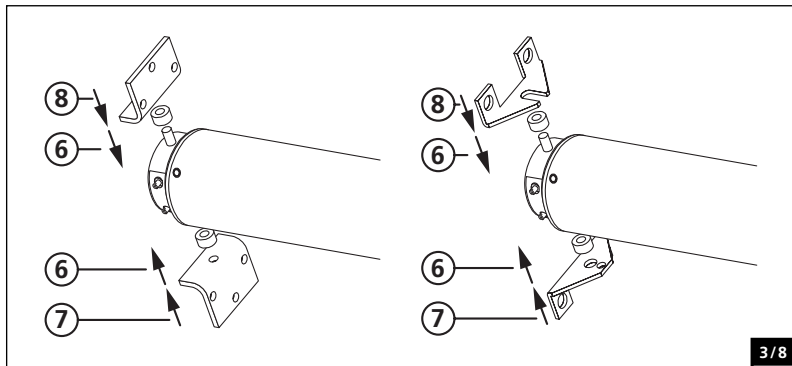
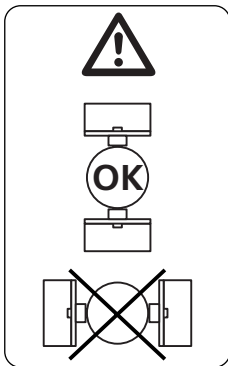
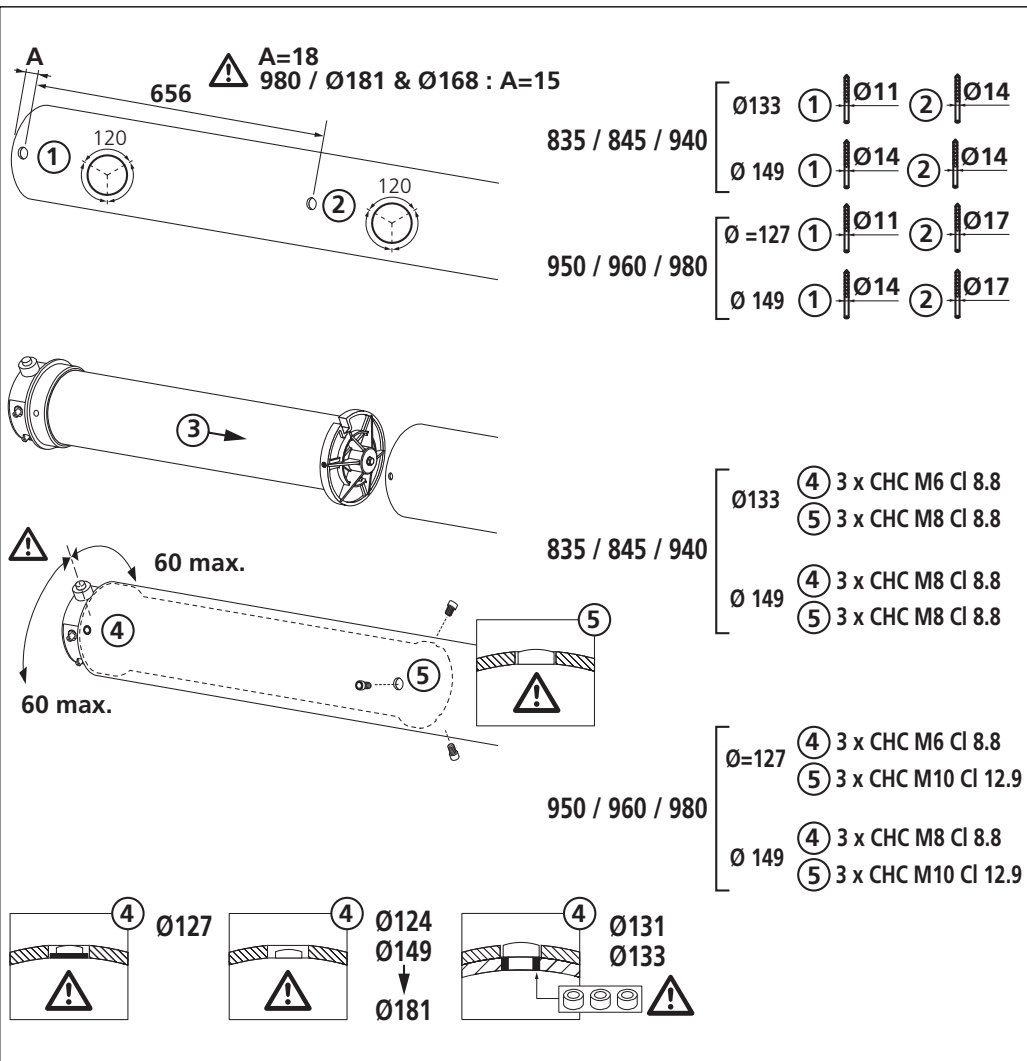

### 3 INSTALLATION - FITTING - INSTALLATIE - ANLAGE - INSTALACIÓN - INSTALAÇÃO - INSTALLAZIONE

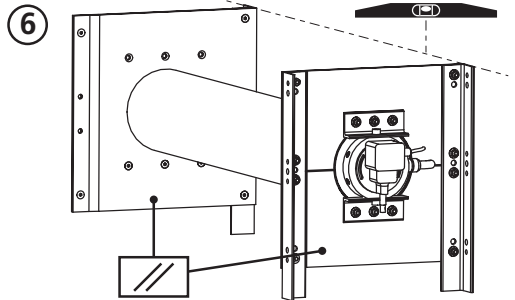
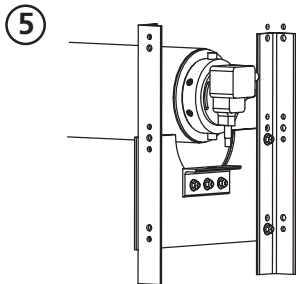
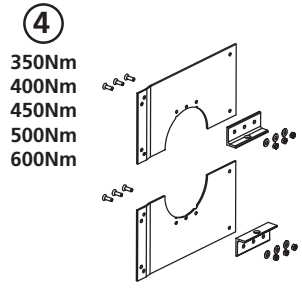
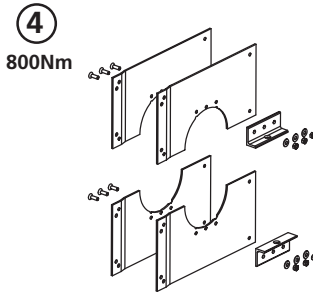
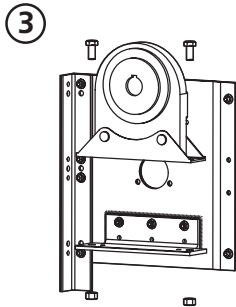
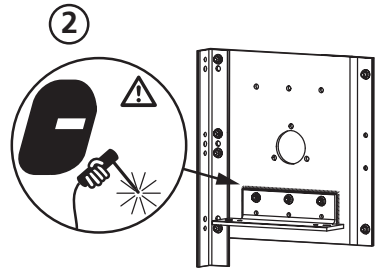
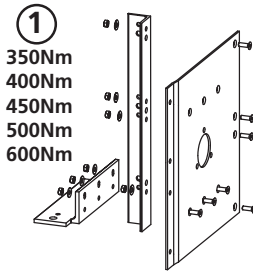
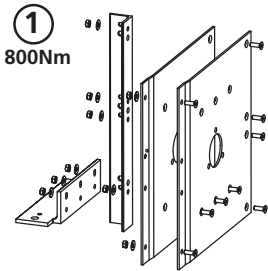

### 4 IDENTIFICATION DES FIN DE COURSES - IDENTIFYING THE LIMITS - IDENTIFICATIE VAN DE EINDAFSTELLING - EINSTELLEN DER ENDLAGEN - IDENTIFICACION DE LOS FINES DE CARRERA - IDENTIFICAÇÃO DO PARAFUSO DE SUBIDA E DESCIDA DOS FINS DE CURSO - IDENTIFICAZIONE DEI FINE DE CORSA

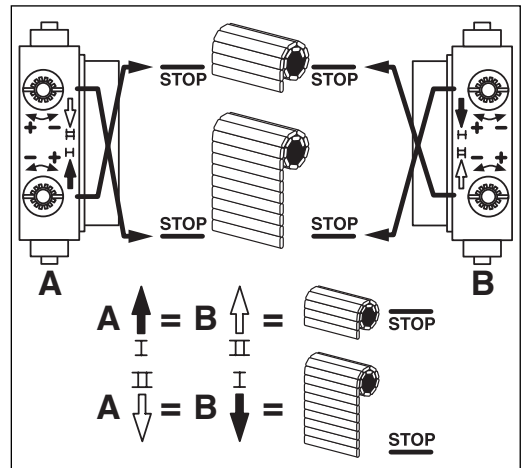
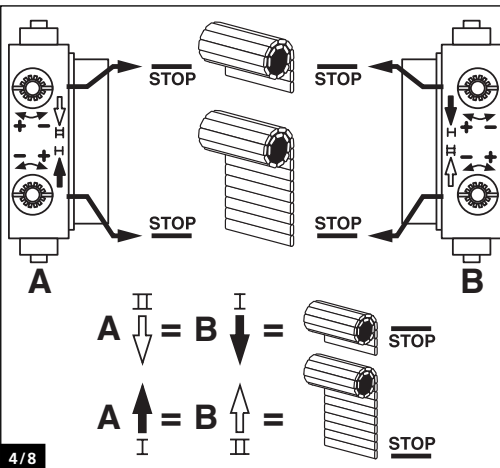

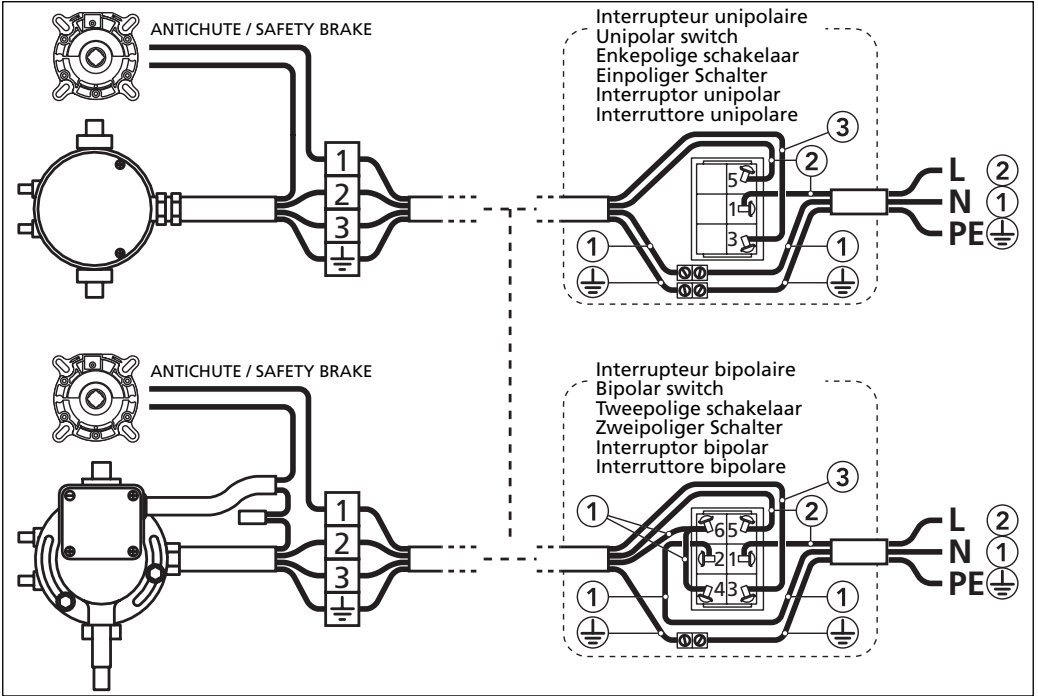

	230V-50Hz	120V-60Hz
<b>PE</b>	VERT / JAUNE GREEN / YELLOW GROEN / GEEL GRÜN / GELB VERDE / AMARILLO VERDE / AMARELO VERDE / GIALLO	VERT GREEN GROEN GRÜN VERDE VERDE VERDE
<b>N</b>	BLEU BLUE BLAUW BLAU AZUL AZUL BLU	BLANC WHITE WIT WEIß BLANCO BRANCO BIANCO
<b>L</b>	MARRON BROWN BRUIN BRAUN MARRÓN CASTANHO MARRONE	ROUGE RED ROD ROT ROJO VERMELHO ROSSO
<b>3</b>	NOIR BLACK SWART SCHWARZ NEGRO PRETO NERO	NOIR BLACK SWART SCHWARZ NEGRO PRETO NERO

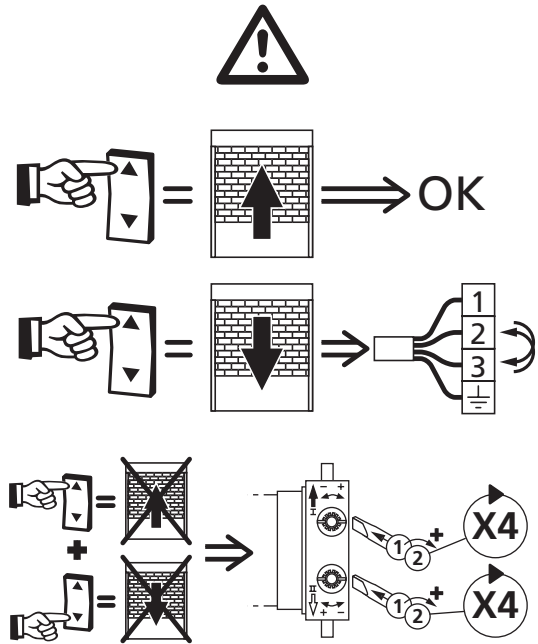

**Δ 3 x 230V**

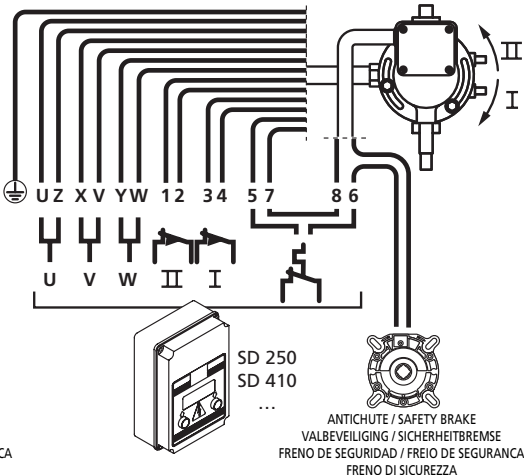
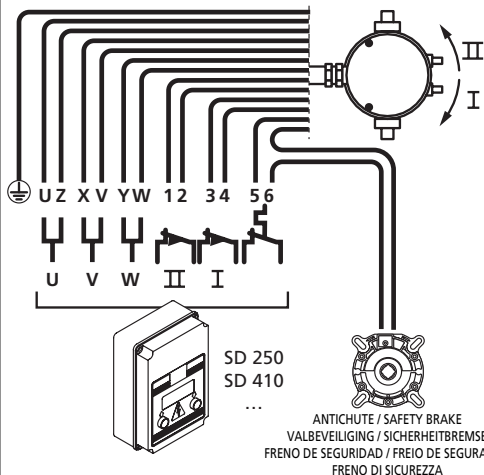

**Δ 3 x 400V**

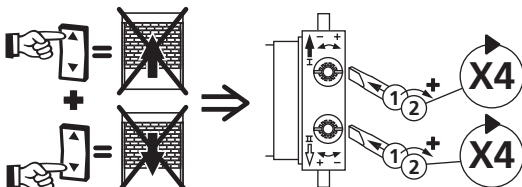
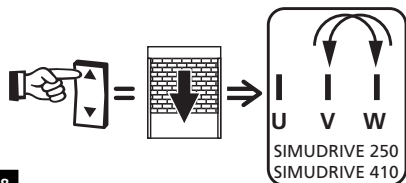
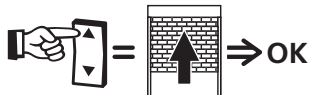
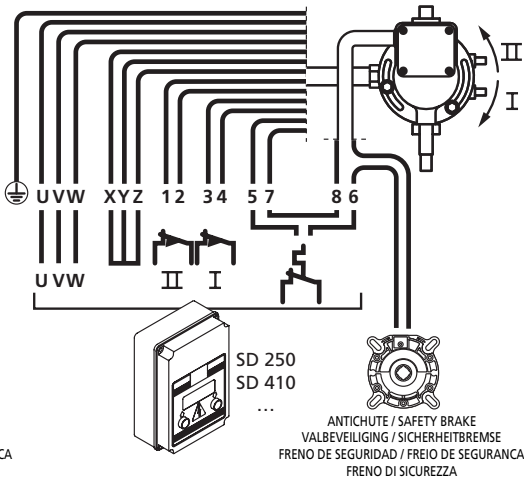
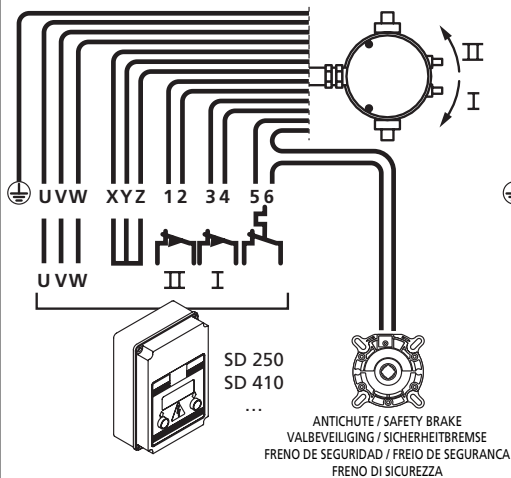



- F** - En situation normale d'utilisation, si le moteur dépasse ces réglages initiaux et s'arrête sur son fin de course de sécurité, appelez votre personnel de maintenance pour inspection de l'installation.
- GB** - In normal use, if the motor goes over its end-limit switch adjustment and stops on its safety limit switch, call your maintenance crew to check your installation.
- NL** - Wanneer in situatie van normaal gebruik de motor deze aanvangsinstellingen overschrijdt en stopt bij de veiligheidsafloop, moet u uw onderhoudspersoneel vragen de installatie te controleren.
- D** - Sollte der Motor bei normalen Betriebsbedingungen diese ursprüngliche Einstellung überschreiten und an seinem Sicherheitsendschalter anhalten, wenden Sie sich sofort an Ihr Wartungspersonal für eine Nachprüfung der Anlage.
- E** - En situación normal de uso, si el motor excede los ajustes iniciales y se detiene en su fin de recorrido de seguridad, llamar al personal de mantenimiento para que controle la instalación.
- P** - Em situação normal de utilização, se o motor ultrapassar os ajustes iniciais e se parar no final do percurso de segurança, peça ao seu pessoal de manutenção para inspeccionar a instalação.
- I** - In una situazione normale di utilizzo, se il motore supera le regolazioni iniziali e si ferma sul fine corsa di sicurezza, contattate il personale di manutenzione per controllare l'installazione



- F** - Dans le cas d'un moteur équipé d'une **manœuvre de dépannage**, le sens de la montée doit systématiquement être indiqué à l'utilisateur final. Si le moteur est combiné à un antichute :
- L'antichute doit être câblé avec le moteur.
  - Il ne faut pas utiliser la manœuvre de dépannage lorsque l'antichute est enclenché.
- GB** - In the case of a motor with **manual override system**, the up direction must systematically be indicated to the end user. If the motor is combined with a safety brake :
- The safety brake must be connected to the motor.
  - The manual override system should not be used when the safety brake is engaged.
- D** - Bei der Verwendung eines Motor **mit Nothandbedienung** muss die Aufwärtsrichtung für den Endverbraucher eindeutig erkennbar sein. Wenn der Motor zusammen mit einer Abrollsicherung verwendet wird :
- Die Abrollsicherung muss mit dem Motor verkabelt werden.
  - Die Nothandbedienung darf nicht benutzt werden, wenn die Abrollsicherung ausgelöst hat.
- NL** - Indien de buismotor voorzien is **van een noodhandbediening**, dan moet visueel aangegeven worden welke draairichting van de slinger de rolport omhoog doet bewegen. Als de buismotor gebruikt wordt in combinatie met een valbeveiling :
- De valbeveiling moet elektrisch worden aangesloten op de motor.
  - De noodhandbediening mag niet worden bedient als de valbeveiling is geactiveerd.
- IT** - Nel caso di un motore **con manovra di soccorso**, il senso dell'aumento deve sistematicamente indicato all'utilizzatore finale. Se al motore è associato un freno di sicurezza :
- Di freno di sicurezza deve essere cablato con il motore.
  - Non bisogna utilizzare la manovra di soccorso quando il freno di sicurezza è attivato.
- E** - En caso de un motor **con accionamiento manual**, la dirección de subida debeseer siempre indicada al usuario final. Si el motor está asociado a un anticaída :
- El anticaída debe estar conectado al motor.
  - El mando manual de emergencia no debe ser accionado cuando el anticaída ha actuado.

